



SAIL MEASUREMENTS FOR:

Name		Name of Measurer	Date Measured
Address		Work Phone:	
City, State, Zip		Home Phone:	
Manufacturer	Model	Year	
Boat Name	Sail Number	Number	Color

The following measurements can be found on your boat's sail plan, rating certificate or in its specifications. If your boat has a rating certificate, please send us a photocopy.

I: _____ J: _____ P: _____ E: _____ LP: _____

Measurement Notes:

- DO NOT** measure your old sails. Sails stretch and distort over the years. However, do include any unique details that pertain to the fit of your old sails to your boat, i.e. corner hardware or spreader patch position. The blank space on the form is for notes.
- Make sure to use a steel or fiberglass reinforced measuring tape. Attach a separate "pull down" or retrieving line on your halyard before hoisting. **Do not rely on the measuring tape to pull the halyard down.**

CIRCLE WHICHEVER APPLIES

BOAT IS: Full Race Race/Cruise Cruise

HANDICAP RULES RACED UNDER: One-Design
IMS PHRF MORC

BOAT'S RIG IS: Masthead Fractional Unstayed

RIG HAS: Running Backstays Babystay

BACKSTAY TENSION SYSTEM IS: Turnbuckle
Block & Tackle Hydraulic

STEP 1: MAIN SAIL MEASUREMENTS

Max. Luff

Check if measured to the band

Main Sail Maximum Luff is measured by pulling the main halyard up as high as possible and then measuring to the top of the gooseneck. If your mast has a black band at the top, raise the tape until it is just at the lower edge of the band. You'll probably have to site the position of the tape from off the boat. If you measured to the black band, check the box.

Straight Line Leech

Next, while the halyard is still all the way up, measure to the bearing point on the outhaul car when it is at the same angle as it is when sailing.

Mast Bend

Finally, measure the amount of mast bend by lowering the tape measure and holding the halyard tight at the intersection of the boom and the mast. Site up and record the maximum number of inches between the mast and the halyard. To help make your judgement, measure the fore-and-aft dimension of the mast and use the column width as a reference. Make sure that the backstay is tensioned before making the measurement.

Max. Foot

Check if measured to the band

The maximum foot length of the main is measured along the boom, between the aft face of the mast and inner end of the black band at the end of the boom. If there is no measurement band, measure to the clew car pin when the car is at it's maximum extended position.

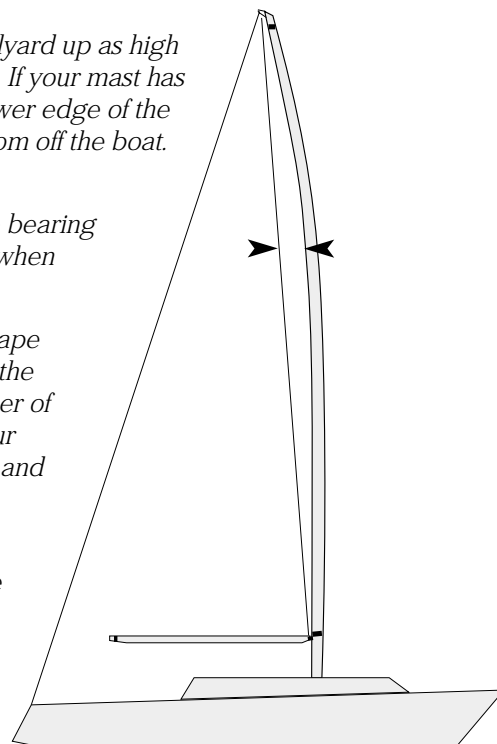



HEADSAIL MEASUREMENTS

I: _____ J: _____

Roller Furling Cover Port / Starboard Side

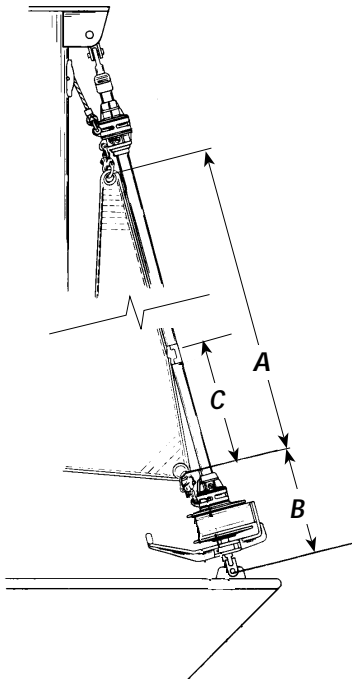

Roller Furlers

When furling system installed, measure "A" — the maximum luff.

Attach tape measure to lower shackle of the halyard swivel. Next, raise swivel as high as possible and measure to the tack shackle on the top of furling unit's drum.

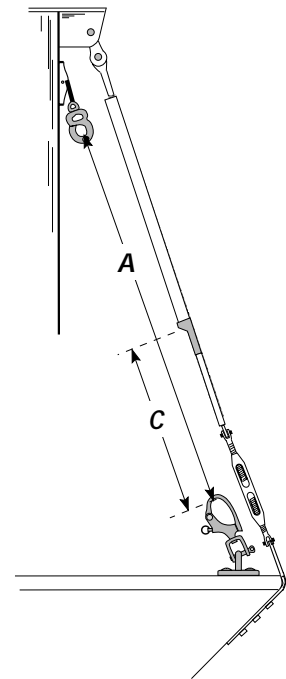
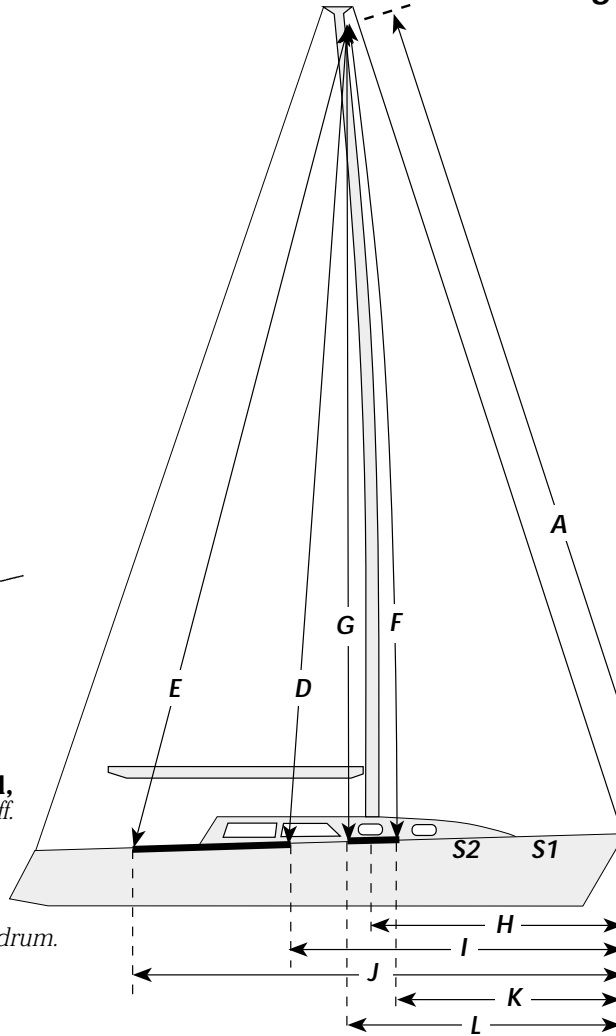

Non-Roller Furling

Measure the max luff by attaching a tape measure to the GENOA halyard shackle and raise the halyard as high as it will go. Measure to the bearing point on the tack fitting.

TENSION THE BACKSTAY TO AVERAGE UPWIND SETTING BEFORE TAKING MEASUREMENTS.

A:	B:	A: Maximum Luff
C:		B: Forestay attachment pin to tack shackle on the roller furling drum.
		C: Bearing point of tack shackle to the feeder in the headstay foil.

With the **GENOA** halyard raised as high as it will go, take the following measurements.

D:	E:	D: Forward end of the genoa track. Make sure tape passes around the shrouds as if it were the leech of a sail. Pull tight when measuring.
F:	G:	E: Aft end of the genoa track; use above procedure.
		F: Forward end of No.3 track
		G: Aft end of No.3 track

Take the following measurements from the bearing point on the **tack fitting**.

H:	I:	H: To the base of the shrouds.
J:	K:	I: To the bearing point of the genoa car at the forward end of the Genoa track
L:	S1:	J: To the bearing point of the genoa car at the aft end of the Genoa track
S2:	S3:	K: To the bearing point of the genoa car at the forward end of the No. 3 track (if separate).
		L: To the bearing point of the genoa car at the aft end of the No. 3 track (if separate).
		S1: To all the stantions in front of the shrouds.

Take the following measurements across the deck:

M:	N:	M: Distance between the foward ends of the port and starboard genoa tracks.
O:		N: Distance between aft ends of the port and starboard genoa tracks.
		O: Distance between the port and starboard shroud bases.

